

Boiler feed pumps

ES series

with mechanical seal or packing gland

PN 40 or PN 63

Research and development with recent test stands



Computer-controlled and fully automated test stands on the premises of Speck in Roth.

Measuring of hydraulics, power requirements, axial thrust, vibrations and NPSH values. Heads of up to 400 m and flow rates of up to 750 m³/h are possible.



Thermal oil test stand with pump surveillance system on the premises of Speck in Roth.

Research of impacts of high temperatures up to 350 °C on the lifetime of the pumps.

Your contacts

Speck Pumpen Walter Speck GmbH & Co. KG

Regensburger Ring 6 – 8
91154 Roth / Germany
Phone: +49 9171 809 0
Fax: +49 9171 809 10
info@speck.de
www.speck.de

International representatives

→ page 15

Boiler feed pumps made by Speck

ES series

- » Horizontal multistage modular pumps
- » Designed for the delivery and circulation of clear or slightly contaminated liquids
- » Suitable for liquids without abrasive contaminants and without solid particles
- » Shaft bearing with two external rolling bearings
- » Hydraulically balanced impellers
- » Cast iron version and spheroidal graphite cast iron version

With mechanical seal

With packing gland

Nominal pressure PN 40 or PN 63

50 Hz $H_{\max.}$ 630 m / $Q_{\max.}$ 110 m³/h

60 Hz $H_{\max.}$ 400 m / $Q_{\max.}$ 125 m³/h

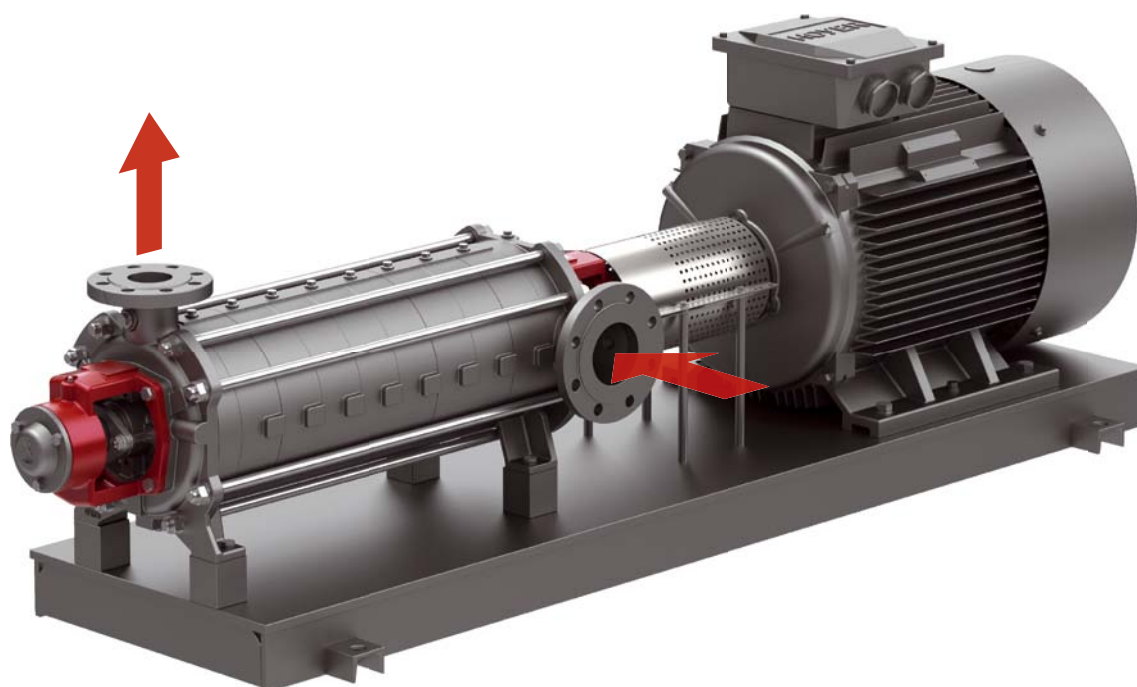

Proven boiler feed pumps for universal applications

Main applications

- » Delivery of hot water in boiler systems
- » Booster stations
- » Water supply units
- » Sprinkler units
- » Cleaning stations
- » Recovering of condensates (water)
- » Extracting palm oil

Modular system

Pumps with mechanical seal

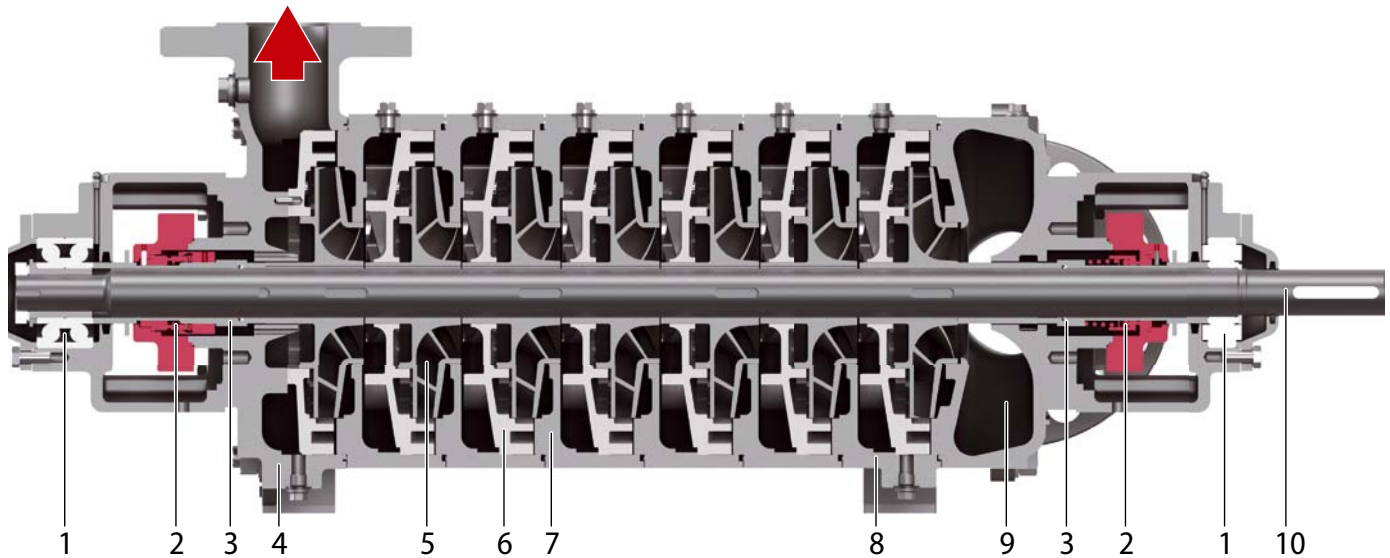

Pumps with packing gland

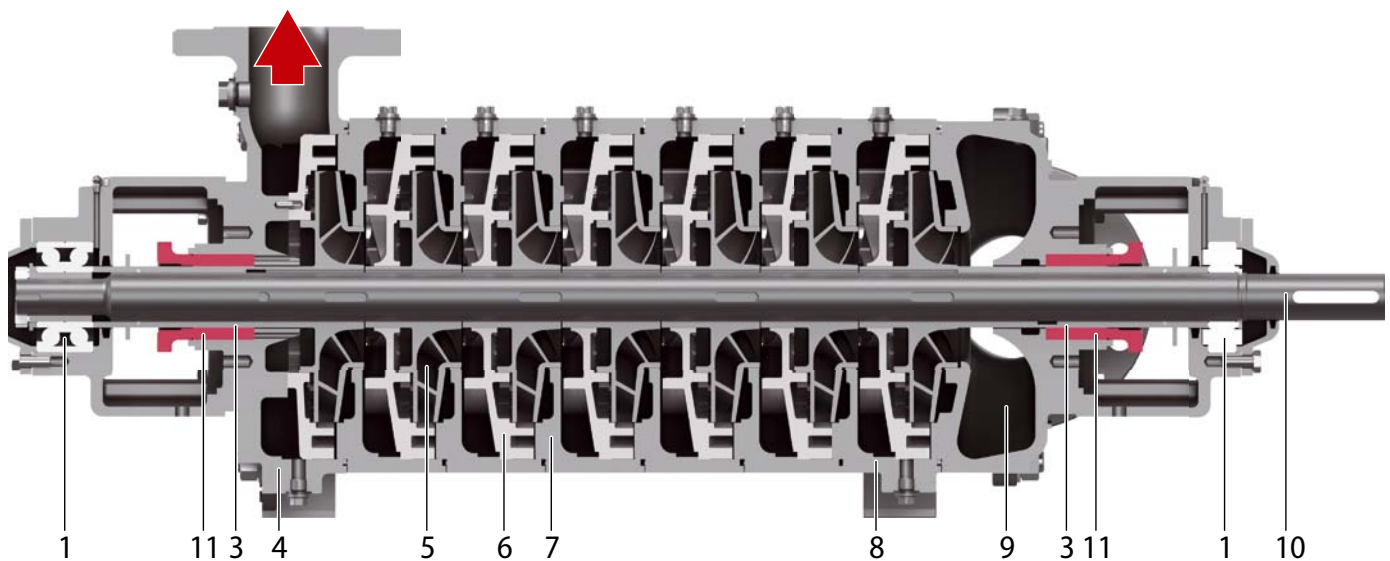

No.	Designation
1	Rolling bearing
2	Mechanical seal
3	Shaft protection sleeve
4	Discharge casing
5	Impeller
6	Diffuser insert

No.	Designation
7	Stage casing
8	Stage casing with foot
9	Suction casing, from stage number 3: rotatable in steps of 90°
10	Shaft
11	Packing gland

Type code

Denomination

Type code Example	ES	40	07	LL	G4-	30	001
Denomination of series							
Pump size							
Number of stages							
Shaft bearing (table 1)							
Shaft sealing (table 2)							
Material design (table 3)							
Counting number							

Table 1 - Shaft bearing

Code	LL	LL	LL
Types / Sizes	ES32 / ES40	ES50	ES65 (PN 40) / ES65 (PN 63)
Design	1 roller bearing, 1 ball bearing	2 ball bearings	1 rolling bearing, 2 angle-seat ball bearings

Table 2 - Shaft sealing

Code	G4	G6	X	SB
Types / Sizes	ES32 / ES40 / ES50 / ES65 (PN 40)	ES65 (PN 63)	ES32 / ES40 / ES50 / ES65 (PN 40)	
Shaft sealing	Mechanical seal			Packing gland
Material	SiC, carbon, FKM or SiC, carbon, EPDM			-
Max. operating pressure	suction side	12 bar 174 psi	16 bar 232 psi	16 bar 232 psi
	discharge side	40 bar 580 psi	63 bar 910 psi	40 bar 580 psi
Max. temperatures / media	SiC, carbon, FKM: Water max. 80 °C, other media max. 120 °C SiC, carbon, EPDM: Water without oil shares max. 120 °C			all media max. 105 °C

Table 3 - Material design

Code	30	30
Types / Sizes	ES32 / ES40 / ES50	ES65
Suction casing	EN-GJS-400-15	
Discharge casing	Spheroidal graphite cast iron	
Stage casing	EN-GJS-400-15	
Stage casing with foot	Spheroidal graphite cast iron	
Diffuser insert	EN-GJL-250	EN-GJL-250
Impeller	Cast iron	Cast iron
Shaft	1.4021 Cr-steel	1.4021 Cr-steel
Shaft protection sleeve	1.4122 CrMo-steel	1.4122 CrMo-steel

Performance range

50 Hz

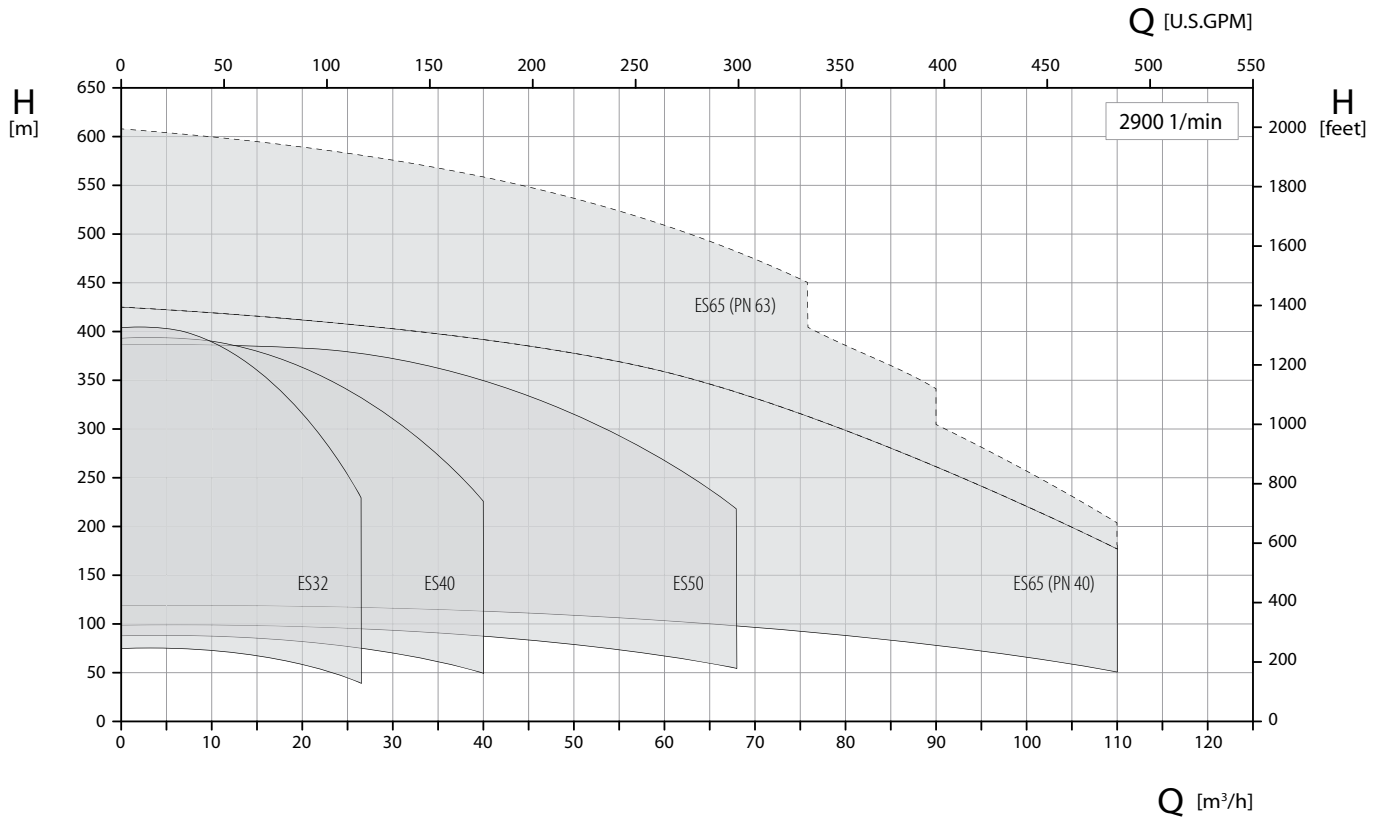

60 Hz

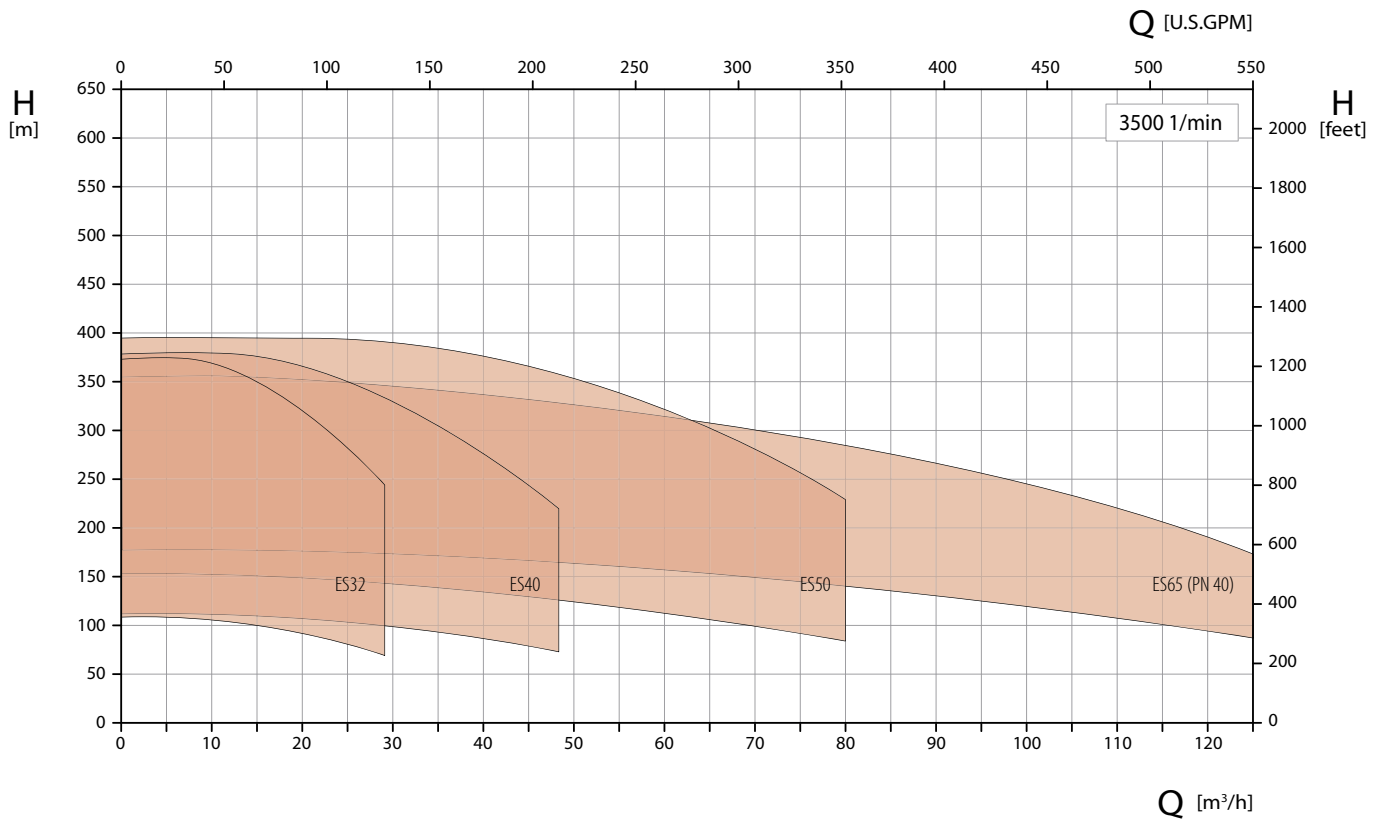

Order-related tests and dimensioning

Pressure tests

Speck carries out the tests below as standard:

Gas pressure test

The gas pressure test is used to prove that the components are leak-proof. All components that bear pressure are tested, such as the discharge casing and the suction casing, stages and mechanical seal casing. The test is carried out with forming gas at 2 bar. The holding time is 15 minutes.

Hydrostatic pressure test

The hydrostatic pressure test is used to prove strength of the components and that the pump is leak-proof. The fully assembled pump is tested. The test is carried out with a hydrostatic test pressure based on prEN 12162; the hydrostatic test pressure corresponds to 1.3 x the nominal pressure (PN16) at 20 °C. The holding time is 30 minutes.

If you want to use pressure tests according to different criteria, please enter them in the request.

Testing the performance

At the customer's request, Speck offers the following tests:

Hydraulic tests

Measurement according to EN ISO 9906, Class II, Acceptance class 2B, Edition March 2013

NPSH test

In this test, the suction-side pressure is gradually reduced until the decrease in the delivered head reaches 3 % at a constant flow rate. At least four flows are evaluated that are spread appropriately over the admissible operating range. The NPSH value is not a guarantee point.

Vibration test

Vibration test according to EN ISO 5199, Edition 2002

The vibration values are measured radially and vertically at every operating point on the bearing casing at the nominal speed and with the corresponding flow rate.

Temperature measurement

The measurement is taken on the motor-side bearing at operating temperature. The operating temperature and the ambient temperature at every operating point measured are documented.

Standard conditions at site

- » Ambient temperature from - 20 °C to + 40 °C
- » Permissible altitude up to 1000 m above sea level

Deviations from the site conditions specified herein must already be disclosed in the inquiry.

Dimensioning

Assessment of the maximum pump outlet pressure

The pump outlet pressure at the pump outlet nozzle depends on

- » the pump inlet pressure
- » the density of the medium to be pumped

The maximum pump outlet pressure $p_{2\max\text{ op}}$ is calculated using the formula:

$$p_{2\max\text{ op}} = p_{1\max\text{ op}} + \rho \cdot g \cdot H \cdot 10^{-5}$$

With:

- $p_{2\max\text{ op}}$ = maximum pump outlet pressure [bar]
- $p_{1\max\text{ op}}$ = maximum pump inlet pressure [bar]
- ρ = density of the medium to be pumped [kg/m³]
- g = gravitation constant [m/s²]
- H = maximum total head at zero flow or at the peak of the pump's characteristic curve [m]

Pumps must be selected and operated in a way which ensures that the maximum pump outlet pressure does by no means exceed the maximum permissible operating pressure of the casing $p_{\text{all w c}}$ at operating pressure.

This also applies to commissioning while the discharge valve is closed.

Simple and optimal configuration software

SPAIX selection program

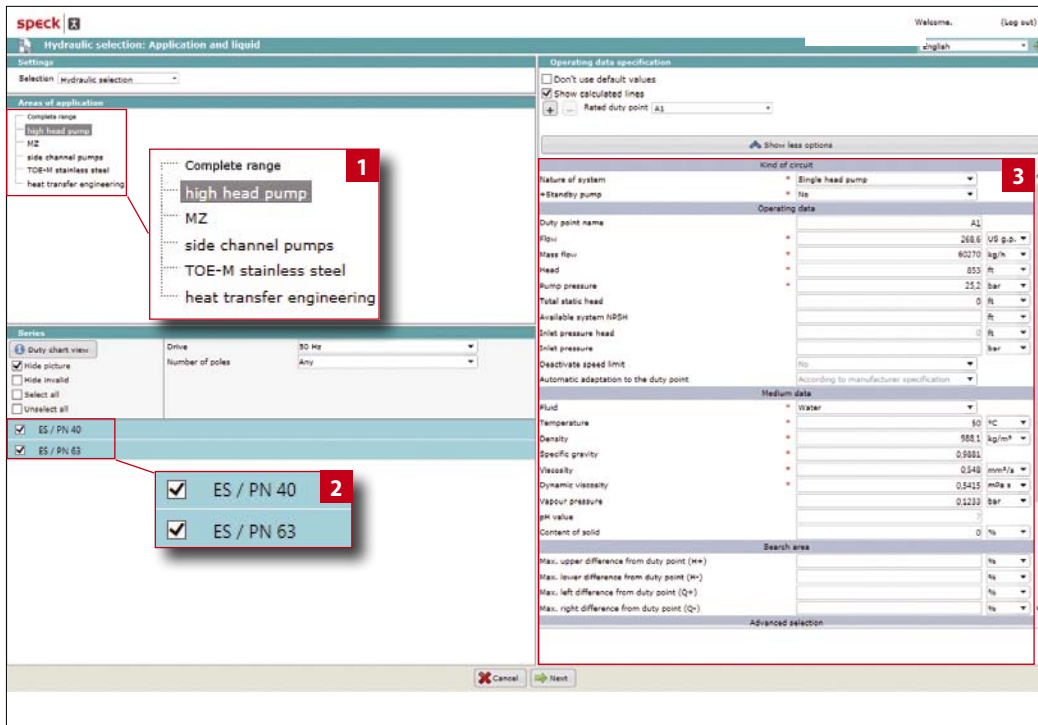

The software allows you to configure heat transfer pumps, side channel pumps and boiler feed pumps via your Internet browser. As well as design details, the system will also request operating details and details about the medium to be pumped.

Ideal for system planners

Speck now also offers the latest version 4 of the renowned SPAIX design software.

We make the program available to authorised customers who can pre-select the pumps within their system.

The web-based software always accesses an up-to-date database.

Easy pre-selection

The configuration system avoids a wide range of selection parameters with regard to design, sealing systems, hydraulics, operating conditions and media.

The software has language options for German and English.

Checking the pre-selection

When the order is submitted, the customer's choices are double-checked to ensure that your project requirements are met.

1 List of all pump designs that can be configured in the software

2 List of all series within the pump designs

3 Selection parameters operating parameters and medium data in the first instance

4 Characteristic curve depending on hydraulic selection generated



Characteristic curve depending on hydraulic selection

Documentation based on the selection program

speck		Data Sheet Boiler feed pumps ES 6507		Quotation Created on Rev.:	Item Page 1 / 4
SPECK PUMPEN Systemtechnik GmbH Regensburger Ring 6 - 8 D-91154 Roth Tel.: 09171/809-0 Fax: 09171/809-10 www.speck.de					
Customer	vom		Kontakt	Editor	Item
City			Phone	Phone	Page 2 / 4
Enquiry			Fax	Fax	
Project			E-mail	E-mail	
Operating Data					
1 Fluid	Water	Flow rate	rated	269 US g.p.m.	Speed
2 Corrosive matters	keine/hot	min / max	80,7 / 426,2 US g.p.m.	Hydr. efficiency	60,82 %
3 Abrasive matters	keine/hot	Inlet	0 bar (0)	hydr. power cons.	70,05 kW
4 Solids	0	Disch.	25,12 bar (0)	Max. operating pressure	28,4 bar (0)
5 Oper. Temp. IW / IS	50 °C	Head	850,3 ft	Start-up temp.	
6 Density at tw	988,1 kg/m ³	Pressure differential	25,12 bar (0)	Flow rate at cold start	US g.p.m.
7 Kin. viscosity at IW / IS	0,548 mm ² /s	NPSH	System required	Total abs. power at cold start	kW
8 Vapor press. at IA	0,1233 bar	Spacer length	6,68 ft		
9 PH value	7				
Installation / Environment					
10 Building / Outside	Gebäude	Altitude	< 3281 ft	Amb. Temp. min	20 / 40 °C
11 under roof yes/no	Ja / Yes	Hazardous area		rel. Humidity	<55 %
Pumps					
12 No of stages Impeller-Ø	mm	6	175	Impeller type	Pressure rating
13 1	205	7	175	direction of rotation	nom. diam. DN
14 2	195	8			Standard
15 3	175	9			EN 1092-2
16 4	175	10		Delivery port	Pressure rating
17 5	175	11			nom. diam. DN
					Standard
					EN 1092-2
Accessories					
18	Motor		Shaft seal		Base plate
19 Make	Type	Number of poles	GRD NU045R0-INB045S1-AQ1VGG	Description	
20 Specific design			Max. 120 °C / 63 bar	Specific design	
21 Rated power	kW	Degree of prot	±5%	Coupling	Length
22 Rated current	A	Frequency	±2% Hz	Make	Width
23 1-phase / 3-phs	V	Voltage	V	Series	
24 Sound pressure level	dB(A)	Mounting		Frame size	Coupling protection
25 Explosion protection				Spacer length	mm
Materials					
26 Suction casing	EN-GJS-400-15	Discharge casing	EN-GJS-400-15		
27 Stage casing	EN-GJS-400-15	Suction stage with foot	EN-GJS-400-15		
28 Diffuser insert	EN-GJL-250	Impeller	EN-GJL-250		
29 Bearing support	EN-GJL-250	Bearing cover	EN-GJL-250		
30 Shaft	1.4122	O-ring	Viton		
31					
32					
Tests and Inspections					
33	Material Tests		Certificate		Qty
34 Suction casing	keine	kein	Hydrost. Pressure Test	Intern	kein alle
35 Discharge casing	keine	kein	Gas Pressure Test	Intern	kein alle
36 Stage casing	keine	kein	Performance curve	Keine	kein alle
37 Suction stage with foot	keine	kein	NPSH-Measurement	Keine	kein alle
38 Diffuser insert	keine	kein	Final check	Intern	kein alle
39			Vibration temperature	Keine	kein alle
40				Keine	kein alle
41				Keine	kein alle
			Max. operating pressure	63 bar / 20°C	X 1 Factor 1,3 test time 30 min
Shipping data					
42	Net weight appr.	kg	Gross weight appr.	kg	Motor color
					Motor color
Documentation					
43	Dimensional drwg.	Cross sect. drwg.	Performance curve No.	Oper & Instruct. Man.	Other (see attached)
44	Rp 8.30. xxx	E 4022. xxx	KL 10.90.130	DE 1096.0902	
Remarks					
45	motor article				
46	1) Motor equipment corresponds to ISO 9908				
	2) According to EN 10204				
	3) Nuke casing & casing cover				
	4) Without NPSH test				
	5) Scope of deliv. to price sheet				

Technical data sheet (example)

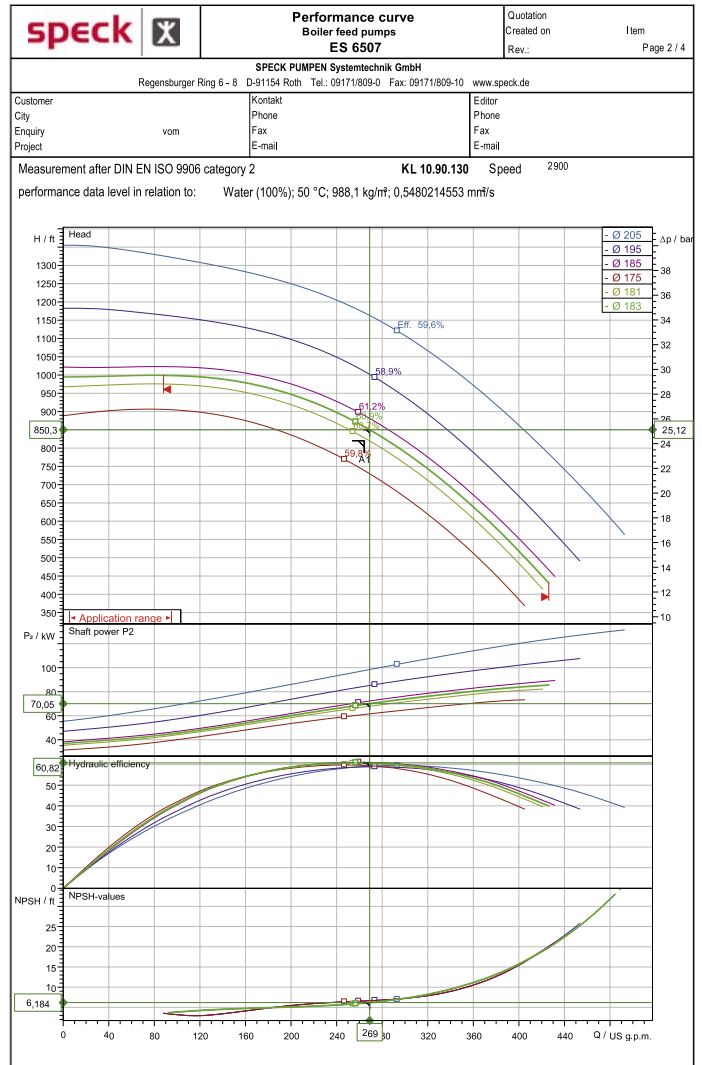

Characteristic curve (example)

speck		Dimension drawing Boiler feed pumps ES 6507		Customer City	Kontakt Phone Fax E-Mail	Editor Phone Fax E-Mail																																														
Quotation		SPECK PUMPEN Systemtechnik GmbH Regensburger Ring 6 - 8 D-91154 Roth Tel.: 09171/809-0 Fax: 09171/809-10 www.speck.de		Created on 2015-07-09 Item Rev. 2015-07-09 Page 4 / 4																																																
Pumpe freie Welle	Motor		<table border="1"> <thead> <tr> <th colspan="2">Anschlüsse</th> <th colspan="2">Dimensions in mm</th> </tr> </thead> <tbody> <tr> <td>Suction port</td> <td>EN 1092-2</td> <td>Delivery port</td> <td>EN 1092-2</td> <td>DNS</td> <td>100</td> </tr> <tr> <td>DN 100 PN 16</td> <td>DN 65 PN 40</td> <td>IS</td> <td>24</td> <td>DS</td> <td>220</td> </tr> <tr> <td>ø D1 180 mm</td> <td>ø D1 145 mm</td> <td>IS</td> <td>24</td> <td>BND</td> <td>6E</td> </tr> <tr> <td>ø D2 19 mm</td> <td>ø D2 19 mm</td> <td>DD</td> <td>18E</td> <td>DD</td> <td>18E</td> </tr> <tr> <td>D2 x 8</td> <td>D2 x 8</td> <td>ID</td> <td>24</td> <td>a</td> <td>51C</td> </tr> <tr> <td></td> <td></td> <td>m1</td> <td>46E</td> <td>m2</td> <td>38E</td> </tr> <tr> <td></td> <td></td> <td>l</td> <td>102E</td> <td></td> <td></td> </tr> </tbody> </table>				Anschlüsse		Dimensions in mm		Suction port	EN 1092-2	Delivery port	EN 1092-2	DNS	100	DN 100 PN 16	DN 65 PN 40	IS	24	DS	220	ø D1 180 mm	ø D1 145 mm	IS	24	BND	6E	ø D2 19 mm	ø D2 19 mm	DD	18E	DD	18E	D2 x 8	D2 x 8	ID	24	a	51C			m1	46E	m2	38E			l	102E		
Anschlüsse		Dimensions in mm																																																		
Suction port	EN 1092-2	Delivery port	EN 1092-2	DNS	100																																															
DN 100 PN 16	DN 65 PN 40	IS	24	DS	220																																															
ø D1 180 mm	ø D1 145 mm	IS	24	BND	6E																																															
ø D2 19 mm	ø D2 19 mm	DD	18E	DD	18E																																															
D2 x 8	D2 x 8	ID	24	a	51C																																															
		m1	46E	m2	38E																																															
		l	102E																																																	

Dimensional drawing (example)

Save projects

Interim configuration results such as characteristic curves, scale drawings or technical data sheets can be saved as a project and generated as a pdf file.

ES32 / ES40 / ES50 – Dimensions

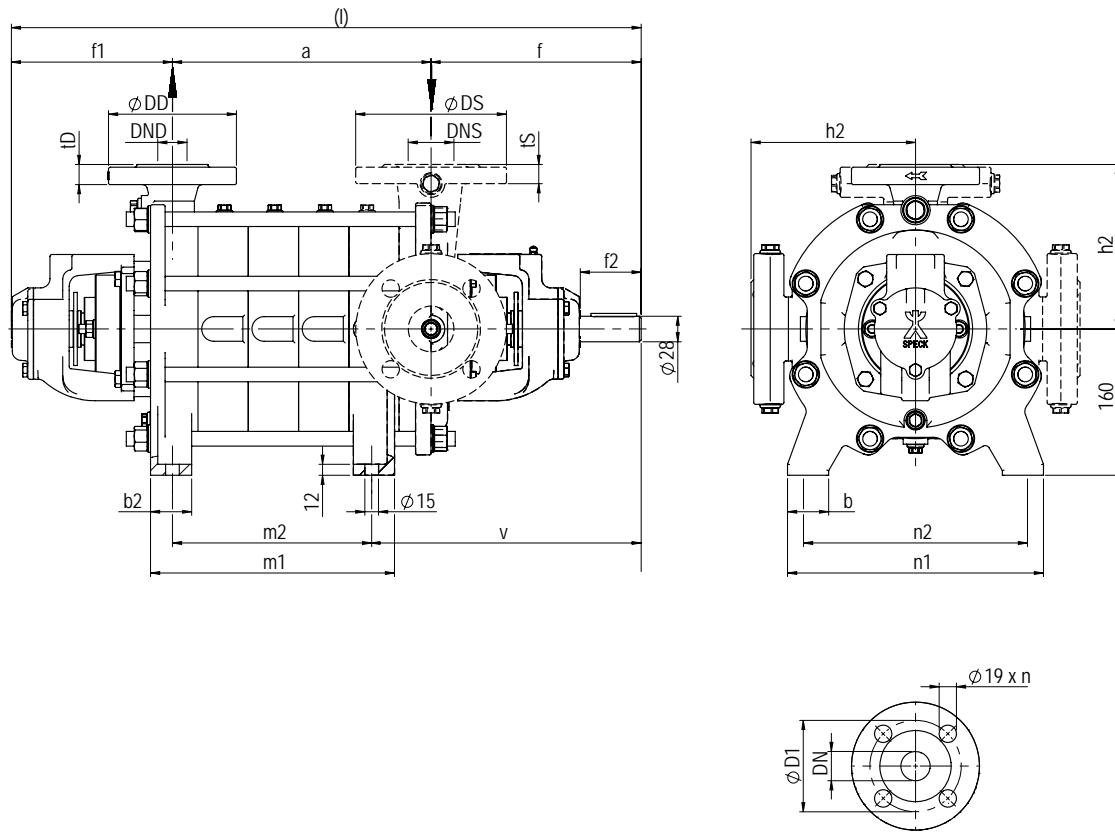

ES32 | PN 40

Size	a	m1	m2	(l)	b2	Ød	f1	f	v	h2
ES3202	118	103	53	522						
ES3203	173	158	108	577						
ES3204	228	213	163	632						
ES3205	283	268	218	687						
ES3206	338	323	273	742	45	28	174	230	295	180
ES3207	393	378	328	797						
ES3208	448	433	383	852						
ES3209	503	488	438	907						
ES3210	558	543	492	962						
ES3211	613	598	548	1017						

Discharge flange PN 40				
DND	DD	D1	n	tD
DN 32	140	100	4	22

Suction flange PN 16				
DNS	DS	D1	n	tS
DN 50	165	125	4	21

ES40 | PN 40

Size	a	m1	m2	(l)	b2	Ød	f1	f	v	h2
ES4002	135	115	55	597						
ES4003	195	175	115	657						
ES4004	255	235	175	717						
ES4005	315	295	235	777						
ES4006	375	355	295	837	50	32	197	265	345	180
ES4007	435	415	355	897						
ES4008	495	475	415	957						
ES4009	555	535	475	1017						

Discharge flange PN 40				
DND	DD	D1	n	tD
DN 40	150	110	4	19

Suction flange PN 16				
DNS	DS	D1	n	tS
DN 65	185	145	4	21

ES50 | PN 40

Size	a	m1	m2	(l)	b2	Ød	f1	f	v	h2
ES5002	153	133	63	625						
ES5003	218	198	128	690						
ES5004	283	263	193	755						
ES5005	348	328	258	820	55	32	197	275	365	200
ES5006	413	393	323	885						
ES5007	478	458	388	950						
ES5008	543	523	453	1015						

Discharge flange PN 40				
DND	DD	D1	n	tD
DN 50	165	125	4	25

Suction flange PN 16				
DNS	DS	D1	n	tS
DN 80	200	160	8	25

ES65 – Dimensions

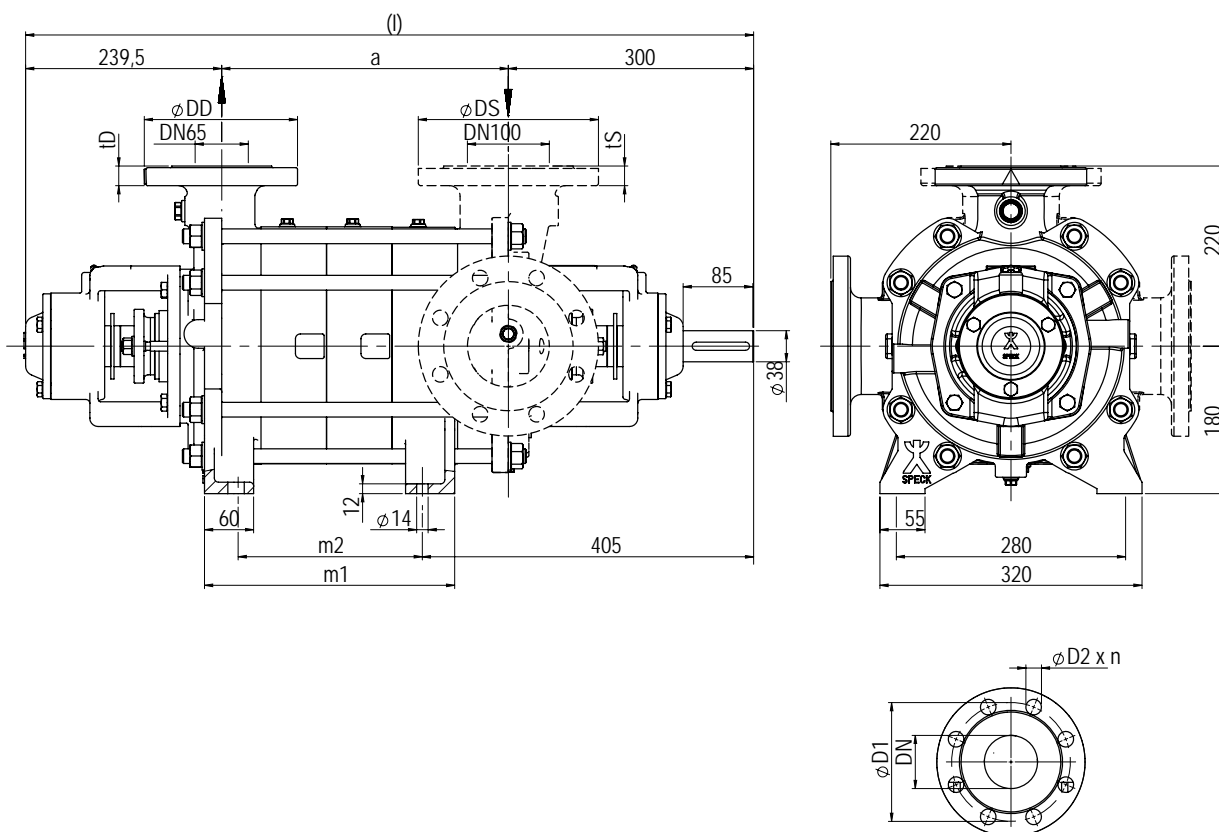

ES65 | PN 40

Size	a	m1	m2	(l)
ES6502	190	146	65	730
ES6503	270	226	145	810
ES6504	350	306	225	890
ES6505	430	386	305	970
ES6506	510	466	385	1050
ES6507	590	546	465	1130

Discharge flange PN 40						
DND	DD	D1	n	tD	D2	
DN 65	185	145	8	24	19	

Suction flange PN 16						
DNS	DS	D1	n	tS	D2	
DN 100	220	180	8	24	19	

ES65 | PN 63

Size	a	m1	m2	(l)
ES6505	430	386	305	970
ES6506	510	466	385	1050
ES6507	590	546	465	1130
ES6508	670	626	545	1210
ES6509	750	706	625	1290
ES6510	830	786	705	1370

Discharge flange PN 63						
DND	DD	D1	n	tD	D2	
DN 65	205	160	8	28	23	

Suction flange PN 63						
DNS	DS	D1	n	tS	D2	
DN 100	253	200	8	33	23	

Flanges

Flanges in acc. with EN 1092 PN 40.

Flanges in acc. with EN 1092-2, drilled in acc. with ANSI 150 lbs or 300 lbs on request.

Direction of rotation

Direction of rotation is clockwise with view towards pump shaft

Connections

Position of inlet and outlet nozzle

The outlet nozzle is always on the top. The inlet nozzle can be rotated 90°.

	Number of stages	
	2	≥ 3
Position of inlet nozzle	Nozzle at the side	Nozzle at the side / on top
Position of outlet nozzle	on top	on top

Inlet nozzle at the side

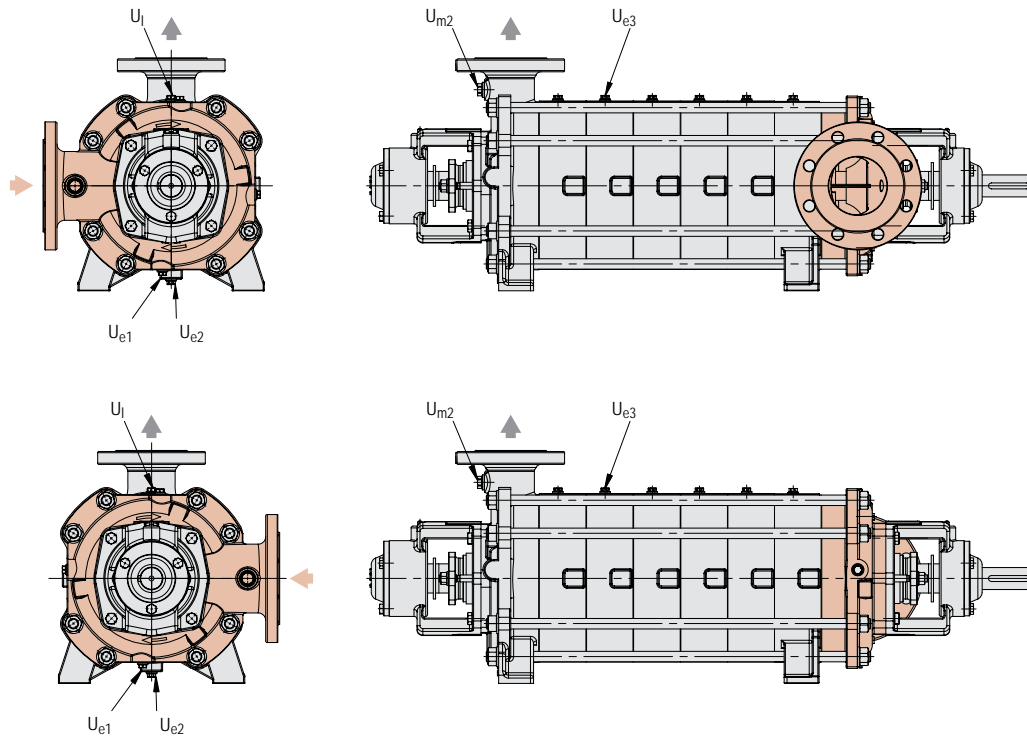

Inlet nozzle on top

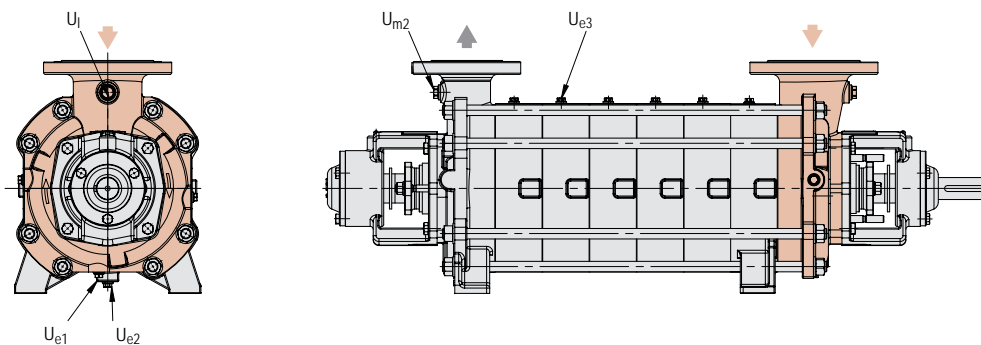

Designation	Connection	Sizes		
		ES32	ES40/ ES50	ES65
U_{e1}	Drainage (screw plug)	G 1/4	G 1/4	G 1/4
U_{e2}	Drainage (screw plug)	-	G 1/4	G 1/4
U_{e3}	Drainage (screw plug)	G 1/4	G 1/4	G 1/4
U_i	Vent (screw plug)	G 1/4	G 1/4	G 1/4
U_{m1}	Pressure gauge connection	G 3/8	G 3/8	G 1/2
U_{m2}	Pressure gauge connection	G 1/2	G 1/2	G 1/2

Your notes

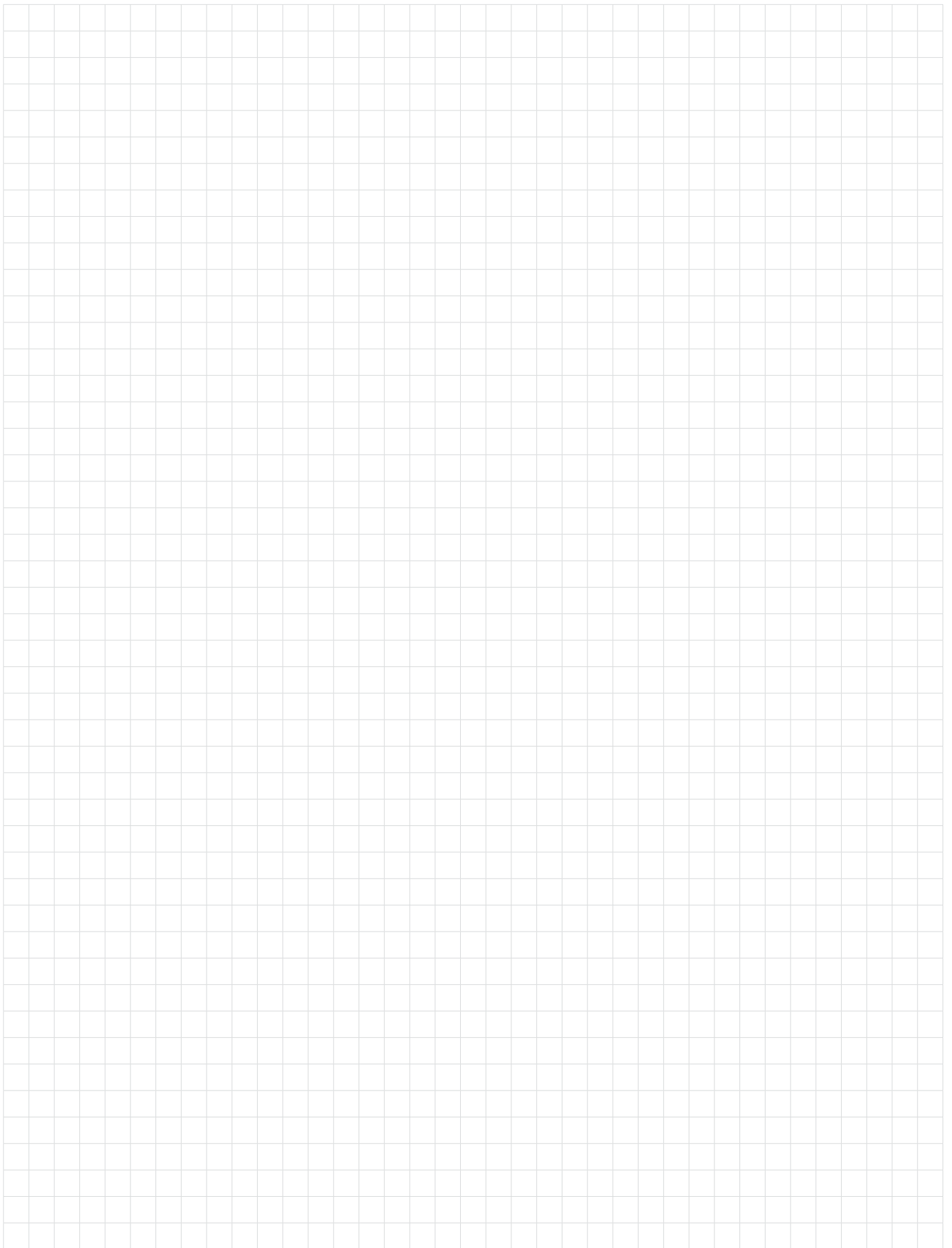

Your notes



Representations

- Produktion / Production
- Vertrieb / Sales
- Service / Service

■ □ ○ Speck Pumpen Walter Speck GmbH & Co. KG

**Speck Pumpen
Systemtechnik GmbH**
**Speck Pumpen
Vakuumentchnik GmbH**
Regensburger Ring 6 - 8, 91154 Roth
T: +49 9171 809 0
F: +49 9171 809 10
info@speck.de
www.speck.de

□ **Speck Office Lagenfeld**
Robert-Koch-Straße 22
40764 Lagenfeld
T: +49 2173 914 560
info@huckauf.de
www.huckauf.de

□ **Speck Office Nord
Ingenieure Willy Wandrach GmbH**
Flurstraße 105
22549 Hamburg
T: +49 40 398 624 0
F: +49 40 398 624 28
info@speck-nord.de
www.speck-nord.de

International

A Austria

□ **Tuma Pumpensysteme GmbH**
Eitnergasse 12
1230 Wien
T: +43 191 493 40
F: +43 191 414 46
sales@tumapumpen.at
www.tumapumpen.at

AUS Australia

□ **Speck Subsidiary**
□ **Speck Industries Pty Ltd.**
Unit 2
6 Glory Road
Gnangara WA 6077
T: 1300 207 380
T: +61 8 6201 1286
sales@speckaustralia.com
www.speckaustralia.com

Speck Subsidiary

□ **Speck Industries Pty Ltd.**
11 Havelock Road
Bayswater VIC 3153
Melbourne
T: 1300 207 380
T: +61 8 6201 1286
sales@speckaustralia.com
www.speckaustralia.com

B Belgium

*Heat transfer pumps / Pompes pour
fluid thermique*
□ **FLOWMOTION BVBA**
Mergelweg 3
1730 Asse
T: +32 2 309 67 13
F: +32 2 309 69 13
info@flowmotion.be
www.flowmotion.be

□ **SPECK - Pompen België N.V.**
Bierweg 24
9880 Aalter
T: +32 937 530 39
F: +32 932 500 17
info@speckpompen.be
www.speckpompen.be

BR Brazil

□ **Tetralon Ind. e Com. De Equipos.**
Industriais Ltda.
Rua São Caetano, 540, Cambuí
MG, Cep - 37600-000
T: +55 11 408 170 05
RFQ@tetralon.com.br
www.tetralon.com.br

BG Bulgaria

□ **EVROTECH EOOD**
ul. Manastirska 54 A
1111 Sofia
T: +359 2 971 32 73
F: +359 2 971 22 88
office@evrotech.com
www.evrotech.com

CH Switzerland

□ **Huckauf Ingenieure GmbH**
Wagistrasse 21
CH-8952 Schlieren
T: +41 55 4425094
info@huckauf.ch
www.huckauf.ch

□ **HänyTec AG**
Pumpen-Prozesse-Service
Lättfeld 2
6142 Gettnau
T: +41 62 544 33 00
F: +41 62 544 33 10
contact@haenytac.ch
www.haenytac.ch

□ **MEYER ARMATUREN PUMPEN GMBH**
Rigackerstrasse 19
5610 Wohlen
T: +41 56 622 77 33
F: +41 56 622 77 60
info@meyer-armaturen.ch
www.meyer-armaturen.ch

CN China

Speck Subsidiary
□ **jiashan SPECK PUMPS**
Systemtechnik Ltd.
No. 57, Hong Qiao Rd., Huimin Street
No. 4 Economical Developing Zone,
314100 Jiashan Xian,
Zhejiang Province
T: +86 573 847 312 98
F: +86 573 847 312 88
steveche@speck-pumps.cn
www.speck-pumps.cn

CZ Czech Republic

□ **Sigmat spol s.r.o.**
Kosmonautu c.p. 1103/6a
77200 Olomouc
T: +420 585 231 070
F: +420 585 227 072
sigmet@sigmet.cz
www.sigmet.cz

DK Denmark

□ **Pumpegruppen a/s**
Lundtoftegårdsvej 95
2800 Lyngby
T: +45 459 371 00
F: +45 459 347 55
info@pumpegruppen.dk
www.pumpegruppen.dk

E Spain

Speck Subsidiary
□ **SPECK BOMBAS INDUSTRIALES,**
S.L.U.
Trafalgar, 53 despacho 6
Centro de Negocios CNAF
46023 Valencia
T: +34 963 811 094
F: +34 963 811 096
M: +34 618 376 241
ventas@speckbombas.es
www.speck.de

F France

Speck Subsidiary
□ **Speck Pumps Industries S.A.**
Z.I. Parc d'Activités du Ried
4, rue de l'Énergie
B.P. 227
67727 Hoerdex Cedex
T: +33 3 88 68 26 60
F: +33 3 88 68 16 86
info@speckfrance.com

GB Great Britain

□ **Speck ABC UK Ltd**
AreenA House
Moston Road,
Elworth, Sandbach
Cheshire CW11 3HL
T: +44 1270 75 36 06
F: +44 1270 76 44 29
admin@speck-abc.com
www.speck-abc.com

GR Greece

□ **SPECK Hellas**
Salaminos St. 54
17676 Kalithea
T: +30 210 956 500 6
F: +30 210 957 747 3
grecha@speckhellas.gr

I Italy

□ **Speck Industries S.r.l**
Via Garibaldi, 53
20010 Canegrate (MI)
T: +39 0331 405 805
M: +39 339 16 59 440
office@speckindustries.it
www.speckindustries.it

IL Israel

□ **Ringel-Tech Ltd.**
134 Hertz St
P.O. Box 5148
6655530 Tel Aviv
T: +972 368 255 05
F: +972 368 220 41
info@ringel-tech.co.il
www.ringel-tech.co.il

IND India

□ **Flux Pumps India Pvt. Ltd.**
427/A-2, Gultekdi Industrial Estate
Near Prabhat Printing Press
Pune - 411037, Maharashtra
T: +91 020 2427 1023
F: +91 020 2427 0689
M: +91 98504 03114
kiran.kadam@flux-pumps.in
www.flux-pumps.in

J Japan

Speck Subsidiary
□ **Speck Japan Co. Ltd.**
Daisho Bldg. 3F,
2-1-16 Kyomachibori, Nishi-ku
550 - 0003 Osaka
T: +81 6 6486 9633
F: +81 6 6486 9643
info@speckjapan.com
www.speckjapan.com

Speck Subsidiary

□ **Speck Japan Co. Ltd.**
Tokyo Branch
1-21-15
GakuenNishimachi, Kodairashi
187-0045 Tokyo
T: +81 4 2312 1628
F: +81 4 2312 1627
contact@speckjapan.com
www.speckjapan.com

L Luxembourg

*Heat transfer pumps / Pompes pour
fluid thermique*
□ **FLOWMOTION BVBA**
Mergelweg 3
1730 Asse
T: +32 2 309 67 13
F: +32 2 309 69 13
info@flowmotion.be
www.flowmotion.be

MAL Malaysia

□ **Leesonmech**
Engineering (M) Sdn. Bhd.
No. 18 Jalan 18, Taman Sri Kluang,
86000 Kluang, Johor
T: +607 777 105 5
F: +607 777 106 6
sales@leesonmech.com
www.leesonmech.com

N Norway

□ **PG Flow Solutions AS**
P.O.Box 154, 1378 Nesbru
Nye Vakaas Vei 14
1395 Hvalstad
T: +47 667 756 00
F: +47 667 756 01
post@pg-flowsolutions.com
www.pg-flowsolutions.com

NL Netherlands

*Centrifugal pumps /
Centrifugaalpomp*
□ **Speck Pompen Nederland B.V.**
Businesspark 7Poort
Stationspoort 10
6902 KG Zevenaar
T: +31 316 331 757
F: +31 316 528 618
info@speck.nl
www.speck.nl

Vacuum pumps / Vacuümpompen

□ **INDUVAC B.V.**
Cobaltstraat 16
2718 RM Zoetermeer
T: +31 793 633 890
F: +31 793 633 899
info@induvac.com
www.induvac.com

Heat transfer pumps / Pompes pour fluid thermique

□ **FLOWMOTION BVBA**
Mergelweg 3
1730 Asse
T: +32 2 309 67 13
F: +32 2 309 69 13
info@flowmotion.be
www.flowmotion.be

NZ New Zealand

Speck Subsidiary
□ **Speck Industries Pty Ltd.**
Unit 2
6 Glory Road
Gnangara WA 6077
T: +61 8 6201 1286
sales@speckaustralia.com
www.speckaustralia.com

P Portugal

□ **Ultra Control**
Projectos Industriais, Lda.
Quinta Lavi - Armazém 8
Abrunheira
27 10 - 089 Sintra
T: +351 219 154 350
F: +351 219 259 002
info@ultra-control.com
www.ultra-control.com

PE Peru

□ **Representaciones y Servicios en el
Perú S.A.C.**
Jr. Alf. Bernal N° 1081, Interior 2
Lima 31
T: +511 653-7560
ventas@representacionesyserviciosperu.com
www.representacionesyserviciosperu.com

PL Poland

□ **Krupinski Pompy Spółka z
Ograniczona Odpowiedzialnoscia Sp.K.**
ul. Przymiarki 4A
31-764 Krakow
T + F: +48 126 455 684
biuro@krupinskipompy.pl
www.krupinskipompy.pl

RC Taiwan

Speck Subsidiary
□ **Speck Pumps
Technology Taiwan Ltd.**
2Fl., no. 153, Sec. 2
Datong Rd., Xizhi District
New Taipei City
T: +886 286 926 220
F: +886 286 926 759
M: +886 936 120 952
speck86@ms32.hinet.net
www.speck-pumps.com.tw

RCH Chile

□ **W & F Ingeniería Y Maquinas S.A.**
Felix de Amesti 90, Piso 6
Las Condes, Santiago
T: +56 2 220 629 43
F: +56 2 220 630 39
M: +56 9 8 289 222 0
rwendler@wyf.cl
www.wyf.cl

RI Indonesia

□ **PT Roda Rollen Indonesia**
Kompleks Pertokoan Glodok
Jaya No. 30
Jl. Hayam Wuruk,
Jakarta - Pusat
Indonesia, 11180
T: +6221 380 58 59
F: +6221 350 89 77
rudu@rodarollenindonesia.com

ROK Korea

□ **J.C. International Inc.**
Sky Bldg. 91, Jandari-ro.
Mapo-gu
04003 Seoul
T: +82 2 326 2800
F: +82 2 326 2804
jylee@jicnt.co.kr
www.jicnt.co.kr

RO Romania

□ **S.C. Gimsid S.R.L.**
Str. Arcului nr. 9, Arp.2
021031 Bucuresti
T: +40 21 2118701
F: +40 21 2102675
gimsid@gimsid.ro
www.gimsid.ro

S Sweden

□ **Tillquist Group AB**
P.O.Box 1120
16422 Kista
T: +46 859 463 200
F: +46 875 136 95
info@tillquist.com
www.tillquist.com

SK Slovakian Republic

→ Czech Republic (CZ)

SLO Slovenia

□ **Sensor d.o.o.**
Tančeva ulica 16
2000 Maribor
Slovenia
T: +386 2 461 44 60
M: +386 31 649 269
info@sensor.si
www.sensor.si

SGP Singapore

→ Malaysia (MAL) Engineering (M)
Sdn. Bhd.

T Thailand

Speck Subsidiary
□ **FLUX-SPECK Pump Co., Ltd**
181/4 Soi Anamai
Srinakarin Road
Suanluang Bangkok 10250
T: +662 320 256 7
F: +662 322 248 6
thienchai@fluxspeck.com
www.fluxspeck.com

TR Turkey

□ **Speck Pompa
San. ve Tic. Ltd. Sti.**
Girne Mah., Küçükyali Is Merkezi
B Blok No.12 Maltepe
34852 Istanbul
T: +90 216 375 750 5
F: +90 216 375 753 3
M: +90 532 293 010 4
speck@speckpompa.com.tr
www.speckpompa.com.tr

USA USA

Speck Subsidiary
□ **Speck Industries LP**
400 Meadow Lane
Carlstadt
NJ 07072
T: +1 201 569 3114
F: +1 201 569 9607
info@speckamerica.com
www.speckamerica.com

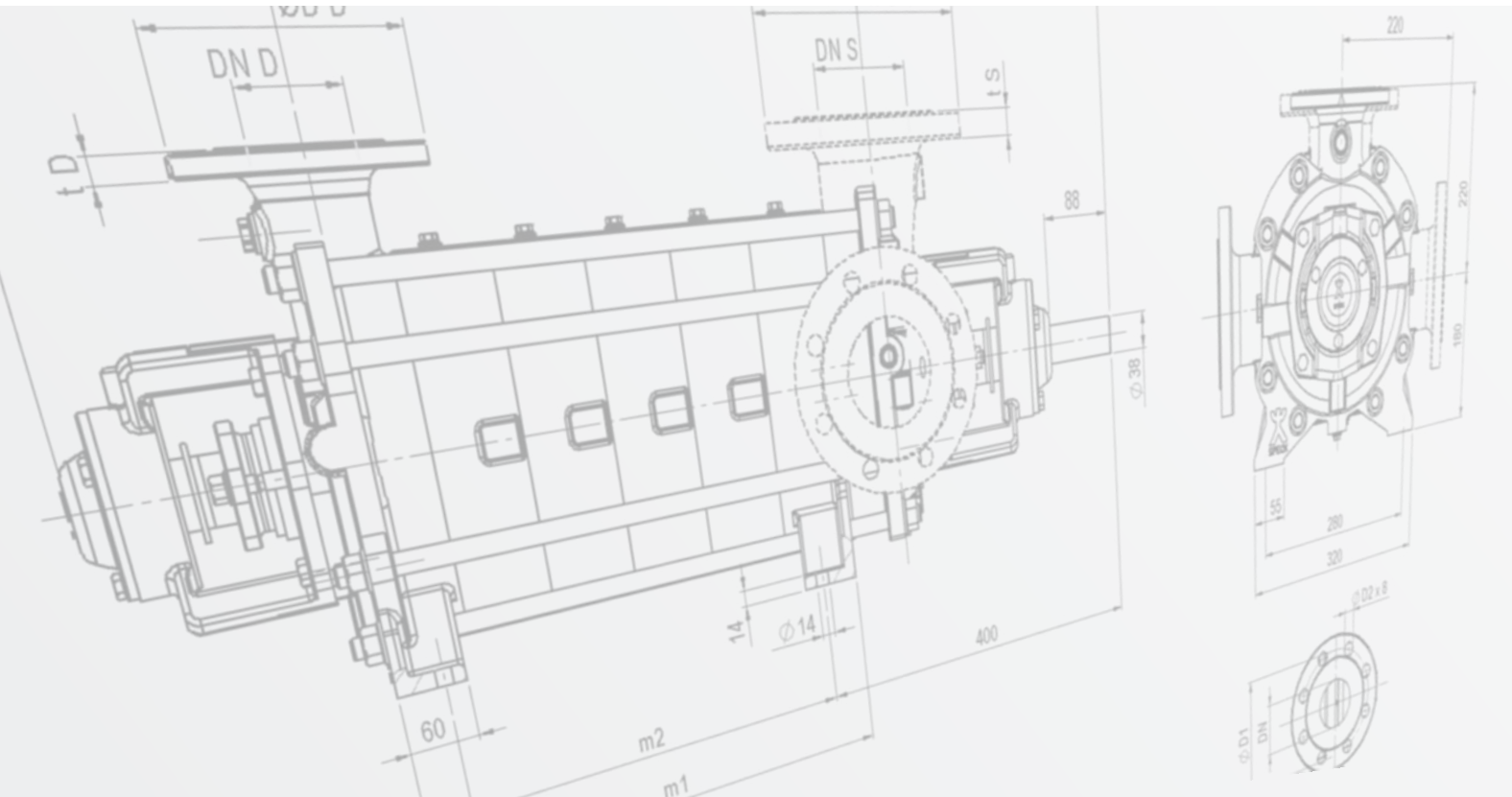

Speck Pumpen Walter Speck GmbH & Co. KG

PO Box 1453 · 91142 Roth / Germany
Regensburger Ring 6-8 · 91154 Roth / Germany
Phone: +49 (0) 91 71 809-0
Fax: +49 (0) 91 71 809-10
info@speck.de
www.speck.de